



No.	Model	Picture	Technical Details
1	T1		<p>27.5" steel frame Huajiu Spoke Suspension fork Shimano 7 speed LED display Aluminum, mechanical disc brake 36V /10.4AH / 350W CHARGING TIME: 4-6 HOURS Mileage: 30-60KM Max speed: 32KM/H</p>
2	T2		<p>26" aluminum frame Suspension fork with lock NECO B.B sets Chaoyang Tire Shimano 8 speed LCD display Aluminum, mechanical disc brake 48V /18AH / 750W CHARGING TIME: 6-10 HOURS Mileage: 50-90KM Max speed: 32KM/H(Pure electric mode) 45KM/H(PAS mode)</p>
3	F1		<p>27.5" Aluminum frame Shimano 8 speed NECO headsets KMC Chain LCD display Aluminum, hydraulic disc brake 36V /7AH / 350W CHARGING TIME: 4-6 HOURS Mileage: 20-40KM Max speed: 25KM/H</p>
4	C1		<p>27.5" Aluminum frame Suntour Suspension fork ZOOM handle bar/stem Shimano 8 speed LCD display Aluminum, mechanical disc brake 48V /14AH / 350W CHARGING TIME: 6-8 HOURS Mileage: 60-90KM Max speed: 32KM/H</p>

5	O1		<p>10" Collapsible Portable Aluminum Frame Aluminum FORK F & R DRUM BRAKE (REAR ABS SYSTEM) LED display 36V/7.5AH/250W CHARGING TIME: 3 HOURS Mileage: 30KM Max speed: 25KM/H</p>
6	B1		<p>16" Collapsible CR-MO steel Frame Aluminum FORK F & R CALIPER BRAKE LED DISPLAY 16" Explosion-proof tyre 36V/7.8AH/250W CHARGING TIME: 4-6 HOURS Mileage: 30-50KM Max speed: 25KM/H</p>
7	S20		<p>20" full suspension aluminum frame Suspension fork ZOOM stem/seat post Prowheel crankset Shimano 8 speed Chaoyang tire Aluminum, hydraulic disc brake 48V /14.5AH / 500W CHARGING TIME: 6-8 HOURS Mileage: 50-90KM Max speed: 32KM/H</p>
8	CL		<p>20" 6061 Aluminum frame Steel fork SHIMANO 7 Speed 20/4.0" CHAOYANG tire Mechanical Disc Brake 48V/14AH /500W CHARGING TIME: 6-7 HOURS Mileage: 50-60KM Max speed: 32KM/H</p>

9	REB		<p>27.5" 6061 Aluminum frame Aluminum rigid fork Shimano 7 speed Mechanical Disc brake 36V/7AH /250W Range:30+Mile by pedaling Max speed: 15MPH by pedaling</p>
10	FMTB		<p>26" 6061 Aluminum frame Aluminum hydraulic suspension lock Shimano 7 speed Hydraulic Disc brake 48V/15AH/750W Range:35 Mile by pedaling Max speed: 20MPH by throttle; 28MPH by pedaling</p>
11	Z1		<p>Aluminum foldable frame Weight 17.5KG Wheels 12" 1260*920*550mm (unfold) 730*630*380mm (folded) Rear and front disc brake (EBS) Rear hub motor 36V/250W Top Speed 25km/h Mileage:35-50KM</p>
12	P1		<p>Frame: 14" folding bike carbon steel frame Motor: 48V*350V high-speed brushless rear motor Controller: 48V vector brushless controller Meter: power display, assist filing Top speed: 25KM/H</p>

700C 36V/10.4Ah BAFANG Mid-Drive Electric Hybrid 8 speed Mountain Bike



Large Multifunction Display

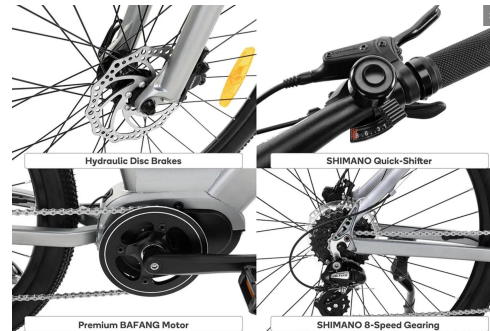

FRAME :	ALLOY FRAME, 27.5**1.95, HT:50*44*170 HEADTUBE RC:468mm
FORK :	ZOOM 27.5"FULL ALLOY SUSPENSION FORK,φ28.6*φ25.4*260L*100W,TRAVEL 80MM
HANDLEBAR :	ALLOY, RISER BAR φ31.8*φ22.2*2.6t*6°,H:30mm,W:620mm
STEM :	ALLOY,EXT:90*10DEGREE,FITTING DIAMETER:φ31.8/φ28.6,H=41mm
HEADSET :	NECO HIDDEN;φ28.6*44*30*H23.5
SADDLE :	LEATHER
SEATPOST :	φ30.4*300mm WITH CLAMP
CRANKSET :	//
BOTTOM BRACKET :	//
CHAIN :	KMC 1/2**3/32**114L, PRESSED TYPE
FREEWHEEL :	SHIMANO HG200-8 8 SPEED CASSETTE, 12T-32T
DERAILLEUR SYSTEM:	SHIMANO RD-ARDM310DLC, STRAIGHT, 8SPEED
SHIFTLEVER:	SHIMANO, R SHIFTLEVER SL-M310, 8SPEED, THUMB SHIFT
BATTERY:	SAMSUNG BATTERY CELL, 36V/10.4Ah, WITH 42V/2A BATTERY CHARGER
DISPLAY:	BAFANG LCD DISPALY, 5 LEVELS ASSIST
MOTOR:	BAFANG MM G330.250/ 36V250W , MID-ENGINE MOTOR, 25KM/H SPEED LIMIT
WHEELSET :	27.5**1.75*36H*13G A/V, DOUBLE WALL ALLOY RIM, , QUANDO F&R QUICK RELEASE HUB
BRAKES :	LOGAN HD-M500 HYDRAULIC DISC BRAKE
BRAKE LEVER :	POWER-OFF BRAKE LEVER
TYRE :	KENDA 27.5**1.95 , 30TPI
PEDALS :	FEIMIN, 9/16" WITH BALL
KICKSTAND:	EQUIPPED

700C 36V/10.4Ah BAFANG Mid-Drive 8 speed Electric Bike



Light-weight 700C alloy step-through frame



Shimano 8-Speed Rear Derailleur



Backlight LCD Display



Shimano Handlebar Shifter



Ergonomically Cushioned Seat

FRAME :	ALLOY FRAME, 700C*460MM,HT ϕ 44/ ϕ 55 \times 140MM,RC:460MM
FORK :	ZOOM ALLOY SHOULDER, 700C MECHANICAL SUSPENSION FORK WITH LOCK ϕ 30*28.6*25.4*228L
HANDLEBAR :	ZOOM ALLOY, ϕ 22.2*620W*60H*10°
STEM :	ALLOY, ADJUSTING STEM,EXT:105mm,H:41mm
HEADSET :	NECO,1-1/8**44*55*30,H=21.8mm
SADDLE :	LEATHER
SEATPOST :	ϕ 27.2*300*2.2T WITH ALLOY CLAMP
CRANKSET :	//
BOTTOM BRACKET :	//
CHAIN :	KMC 1/2**3/32**114L, PRESSED TYPE
FREEWHEEL :	SHIMANO HG200-8 8 SPEED CASSETTE, 12T-32T
DERALLIEUR SYSTEM:	SHIMANO RD-ARDM310DLC, STRAIGHT, 8SPEED
SHIFTLEVER:	SHIMANO, R SHIFTLEVER SL-M310, 8SPEED, THUMB SHIFT
BATTERY:	SAMSUNG BATTERY CELL, 36V/10.4Ah, WITH 42V/2A BATTERY CHARGER
DISPLAY:	BAFANG LCD DISPALY, 5 LEVELS ASSIST
MOTOR:	BAFANG MM G330.250/ 36V250W , MID-ENGINE MOTOR, 25KM/H SPEED LIMIT
WHEELSET :	700C*1.75*32H*13G,DOUBLE WALL ALLOY RIM, A/V, QUANDO F&R QUICK RELEASE HUB
BRAKES :	LOGAN HD-M500 HYDRAULIC DISC BRAKE
BRAKE LEVER :	POWER-OFF BRAKE LEVER
TYRE :	KENDA 700C*40C,30TPI, A/V
PEDALS :	FEIMIN, PLASTIC PEDAL ,9/16" WITH BALL
KICKSTAND:	EQUIPPED

EN15194 CE

700C 36V/7.8Ah Mid-Drive Unisex & Ladies 7 speed Vintage Electric Bike

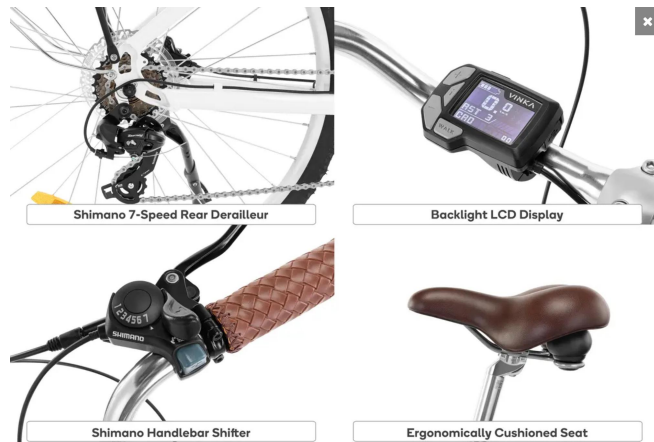

FRAME :	ALLOY FRAME, 700C*40C,HT:50*44*180 RC:478mm ST:31.8*2.2t*470mm
FORK :	ZOOM ALLOY SHOULDER, 700C MECHANICAL SUSPENSION FORK WITH LOCK ϕ 30*28.6*25.4*205L
HANDLEBAR :	ZOOM ALLOY CURVE BAR , 22.2*W540*2.6T,H:130mm
STEM :	ALLOY, ADJUSTING STEM,E:110mm,L:180mm
HEADSET :	NECO, STEEL 1-1/8"*44*50*30,H=25mm
SADDLE :	BROWN LEATHER
SEATPOST :	ALLOY , ϕ 27.2*300*2.2T ALLOY CLAMP
CRANKSET :	//
BOTTOM BRACKET ://	
CHAIN :	KMC 1/2"*3/32"*118L PRESSED TYPE
FREEWHEEL :	SHIMANO AMFTZ5007428, 14T-28T, 7SPEED INDEX
DERALLIEUR SYSTEM:	SHIMANO RD-TY300D, STRAIGHT, 7SPEED
SHIFTLEVER:	SHIMANO R SHIFTLEVER-ASLTX30R7AT, THUMB SHIFT
BATTERY:	36V/7.8Ah BATTERY, WITH 42V/2A CHARGER
DISPLAY:	LED DISPLAY WITH 5 LEVELS ASSIST
MOTOR:	VINKA MID-ENGINE MOTOR, 25KM/H SPEED LIMIT
WHEELSET :	700C*32H*13G, DOUBLE WALL ALLOY RIM, A/V,QUANDO F&R QUICK RELEASE HUB
BRAKES :	LOGAN HD-M500 HYDRAULIC DISC BRAKE
BRAKE LEVER :	POWER-OFF BRAKE LEVER
TYRE :	KENDA 700C*40C,30TPI, A/V
PEDALS :	FEIMIN, PLASTIC PEDAL ,9/16" WITH BALL
KICKSTAND:	EQUIPPED

700C 36V10.4Ah Hybrid Commuter Electric 7 Speed Mountain Bike



- FRAME :** ALLOY FRAME, 700C*18",HEADTUBE;50*44*170,MIDLETUBE 34.9*457*2.2T,RC470mm
- FORK :** ZOOM ALLOY SHOULDER, 700C MECHANICAL SUSPENSION FORK WITH LOCK ϕ 30*28.6*25.4*228L
- HANDLEBAR :** STEEL, RISER BAR, ϕ 22.2*620W
- STEM :** ALLOY,EXT:90*7DEGREE,FITTING DIAMETER: ϕ 31.8/ ϕ 28.6,H=42mm
- HEADSET :** NECO,HIDDEN TYPE; ϕ 28.6*44*30*H23.5
- SADDLE :** LEATHER
- SEATPOST :** STEEL, ϕ 30.4*300mm
- CRANKSET :** PROWHEEL, 1/8"*3/32"*48T*170L
- BOTTOM BRACKET :** NECO SEALED BB SET , BC1.37"*24T
- CHAIN :** 1/2"*3/32""*118L, PRESSED TYPE
- FREEWHEEL :** SHIMANO AMFTZ5007428,14T-28T,7SPEED INDEX
- DERAILLEUR SYSTEM:** SHIMANO RD-TY300D 7 SPEED, STRAIGHT
- SHIFTLEVER:** SHIMANO R SHIFTLEVER - ASLTX30R7AT, THUMB SHIFT
- BATTERY:** 36V/10.4Ah BATTERY, WITH 42V/2A CHARGER
- DISPLAY:** LCD DISPLAY WITH 5 LEVEL ASSIST
- MOTOR:** JIABO REAR BRUSHLESS MOTOR, 36V*250W, 25KM/H SPEED LIMIT
- WHEELSET :** 700C*1.75*32H*13G,A/V,DOUBLE WALL ALLIY RIM, QUANDO F&R QUICK RELEASE HUB
- BRAKES :** LOGAN MECHANICAL DISC BRAKE
- BRAKE LEVER :** ALLOY POWER-OFF BRAKE LEVER
- TYRE :** KENDA 700C*40C 30TPI,A/V
- PEDALS :** NECO 9/16",PLASTIC PEDAL WITH BALL
- KICKSTAND:** EQUIPPED

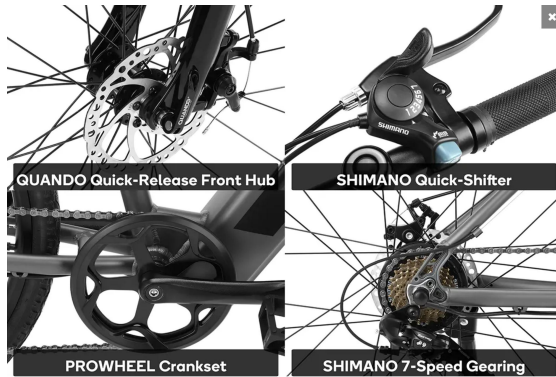

26" City Breeze+ Unisex & Ladies Vintage 7 Speed Electric Bike



Shimano 7-Speed Rear Derailleur

Backlight LCD Display



Shimano Handlebar Shifter



Ergonomically Cushioned Seat

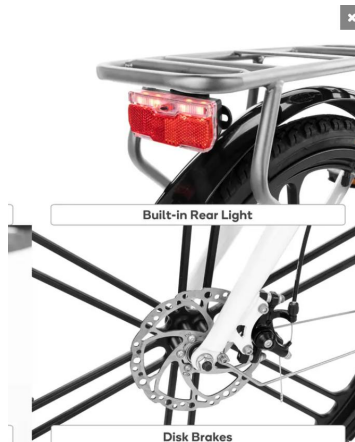

Built-in Rear Light

Disk Brakes

- FRAME :** 26"*1.50 ALLOY FRAME HT:50*44*140,RC:520mm
ST:38.1*2.2*430mm
- FORK :** 26" ALLOY FORK ϕ 28.6* ϕ 25.4*167mm
- HANDLEBAR :** ALLOY, ϕ 22.2*610W*2.2T*60H*35 ϕ 25.4, HOLDING DISTANCE:180mm
- STEM :** ALLOY , E:80,L:180,FITTING DIAMETER: ϕ 25.4* ϕ 25.4*30 ϕ
- HEADSET :** NECO,STEEL,BC1-1/8"*26T, ϕ 25.4*44*30,H:25mm
- SADDLE :** LEATHER
- SEATPOST :** ϕ 27.2*2.4t*265mm, SUSPENSION FOLDING TYPE
- CRANKSET :** PROWHEEL, ALLOY, 1/8"*3/32"*46T*170
- BOTTOM BRACKET :** NECO SEALED BEARING BB SET,BC1.37"
- CHAIN :** 1/2"*3/32"*128L, PRESSED TYPE
- FREEWHEEL :** SHIMANO AMFTZ5007428, 14T-28T, 7SPEED INDEX
- DERALLIEUR SYSTEM:** SHIMANO RD-ARDTZ500GSD, 7SPEED, STRAIGHT
- SHIFTLEVER:** SHIMANO R SHIFTLEVER: SHIMANO-ASLTX30R7A, 7 SPEED, THUMB SHIFT
- BATTERY:** 36V/10.4Ah BATTERY, WITH 42V/2A CHARGER
- DISPLAY:** LCD DISPLAY, 5 LEVER ASSIST
- MOTOR:** JIABO 36V/250W REAR BRUSHLESS MOTOR, ONE-WHEEL TYPE
- WHEELSET :** MAGNESIUM ALLOY ONE-WHEEL SET
- BRAKES :** LOGAN MECHANICAL DISC BRAKE
- BRAKE LEVER :** POWER-OFF BRAKE LEVER
- TYRE :** CST 26"*1.50 30TPI TIRE,A/V
- PEDALS :** 9/16" PLASTIC PEDAL
- KICKSTAND:** EQUIPPED

26" City Breeze Unisex & Ladies Vintage Electric Bike



Battery Power Level Indicator

PROWHEEL Crankset



Ergonomically Cushioned Seat



Easy Handlebar Controller

FRAME :	26**1.50 ALLOY FRAME HT:37*30*160mm,RC:547mm ST:38.1*2.0*475mm
FORK :	STEEL,26**1.50*345mm/φ25.4*φ22.2*195mm
HANDLEBAR :	ALLOY φ25.4*φ22.2*2.2t,H:130mm,W:580mm
STEM :	ALLOY,E40*30*L220mm, FITTING DIAMETER:φ25.4*φ22.2*2.0t
HEADSET :	NECO, φ22.2*30*27*8PCS,H=34
SADDLE :	LEATHER
SEATPOST :	φ27.2*1.4t*300mm,FOLDING TYPE
CRANKSET :	1/2**1/8**36T*165L
BOTTOM BRACKET :	SEALED BEARING TYPE , L:140mm/24.5*84*31.5 , BC1.37"
CHAIN :	1/2**1/8**112L ,PRESSED TYPE
FREEWHEEL :	ATA, 1/2**1/8**16T
DERALLIEUR SYSTEM:	SINGLE SPEED
SHIFTLEVER:	SINGLE SPEED
BATTERY:	36V/10.4Ah BATTERY WITH 42V/2A CHARGER
DISPLAY:	LED DISPLAY, 3 LEVEL ASSIST
MOTOR:	REAR BRUSHLESS MOTOR, 26**36V*250W/13G*36H*M12*140W*205mm, 25KM/H SPEED LIMIT
WHEELSET :	26**1.50*36H*13G DOUBLE WALL ALLOY RIM, A/V, FRONT BOLT-NUT HUB
BRAKES :	LOGAN ALLOY V BRAKE,H=110mm
BRAKE LEVER :	ALLOY,L/R φ22.4, POWER-OFF BRAKE LEVER
TYRE :	CST C1313 26**1.50 30TPI TIRE, A/V
PEDALS :	FEIMIN 9/16" PLASTIC PPEDAL
KICKSTAND:	EQUIPEED

1.



CONFIGURATION

Frame	700C female vehicle, aluminum alloy
Front fork	Aluminum
Handlebar horizontal	Aluminum alloy
Handlebar	Aluminum alloy
Saddle	All black leather, plastic
Crank sprocket	Steel/aluminum
Chain	Steel
Pedal	Plastic
Car brake	Front disc brake, aluminum/steel
Brake handle	Aluminum
Rear derailleur	8-speed, steel/plastic
Rear shift lever	Right 8-speed positioning dial, steel/plastic
Spokes	Steel
Tire	700C*40C, rubber

Inner tube	700C*35C/43C, butyl rubber inner tube, rubber
Motor	36V/250W/26/700C/28 inch sticker, 25KM/H, Hall rear drive, aluminum alloy
Flywheel	8-speed, steel
Front/rear reflector	Plastic
Battery	36V/10.6AH, domestic batteries, ternary
Sensor	Left Double Hall, 12 magnetic steel, steel / plastic
Meter	36V, 27.5/700C general use, 0-3 gears, plastic
Price	

2.



CONFIGURATION

Frame	Monochrome frame, steel
Handlebar horizontal	Steel

Handlebar	Aluminum alloy
Saddle tube	Steel
Saddle	Plastic
Crank sprocket	Steel
Chain	Steel
Car brake	Aluminum
Axial skin	Nexus 3 coaster brake, steel
Motor	Front drive W/O Hall, 700C/36V/250W,25KM/H, with Hall velocimetry, aluminum alloy
Spokes	Copper cap, steel
Tire	28*1.75, rubber
Inner tube	28*1.75, A/V mouth Butyl rubber inner tube, rubber
Flywheel	16T(2.3MM) SILVER(DX), steel
Brake handle	Mechanical brake handle, aluminum
Battery	36V10.4AH, domestic batteries, ternary
Charger	36V2A/European standard power plug, plastic
Controller	36V, new European standard, aluminum
Meter	36V, 700C wheel diameter, 0-5 gears, plastic
Sensor	Right Double Hall, 12 magnetic steel, steel / plastic
Price	

3.



CONFIGURATION

Frame	Aluminum alloy/ aluminum
Handlebar horizontal	Aluminum alloy
Handlebar	Aluminum alloy
Front fork	Disc brake, aluminum
Saddle	Plastic
Rim	A/V nozzle, 27.5* 13G*36 holes, aluminum alloy
Crank sprocket	Steel /aluminum
Pedal	With L R label, steel / aluminum
Car brake	Wear-resistant pads, steel / aluminum
Gate line	Steel/plastic
Spokes	Copper cap, steel
Tire	27.5*2.10, black tire, with "KENDA" mark, rubber
Inner tube	27. 5*2.10, A/V nozzle, butyl rubber inner tube, rubber

Motor	27.5"*36V*250W,13G*36H, Hall disc brake motor in rear drive, aluminum alloy
Flywheel	7-speed positioning, 14T-28T, steel
Rear shift lever	7-speed positioning on the right, steel / plastic
Battery	36V8.7AH / 2900 domestic batteries, ternary
Charger	36V1.5A/, American standard power plug, 2.1DC plug, plastic
Controller	36V15A, aluminum
Meter	36V, 0-3 gears, plastic
Brake handle	Mechanical brake handle, aluminum
Sensor	Left, Double Hall 12 magnetic steel, steel / plastic
Price	

4.



CONFIGURATION

Frame	Monochrome frame, aluminum alloy
--------------	---

Handlebar horizontal	Aluminum alloy
Handlebar	Right folded and retractable, aluminum alloy
Saddle tube	Steel
Saddle	Plastic
Crank sprocket	Steel/aluminum
Chain	Steel
Car brake	Front / rear disc brake, aluminum/steel
Gear shift	6-speed, steel/plastic
Motor	20"*36V*250W/25km/h / Hall high-speed rear motor, aluminum alloy
Spokes	Steel
Tire	Rubber
Inner tube	20"*1.75, A/V mouth Butyl rubber inner tube, rubber
Flywheel	6-speed, steel
Brake handle	Mechanical brake handle, aluminum
Battery	36V6.6AH, domestic batteries
Charger	36V2A/European standard power plug, plastic
Controller	36V, current limiting 12±1A, aluminum
Meter	36V, 0-3 gears, plastic
Sensor	Left double hall, 7 magnetic steel, steel plastic
Price	

reddot design award

N1 Electric Scooter (9 inch)



reddot design award



N1



N1-ABE

reddot design award



reddot design award



Integrated Moulding Frame

Die-casting Magnesium Alloy: light-weight & high strength

reddot design award

3 Seconds Fast Folding

Easily to put into car or carry to metro/bus



Big Capacity Battery

40 Battery cells, longer range

25

Max.speed(km/h)

35

Max.Range(km)

15

N.W (kg)

100

Load (kg)

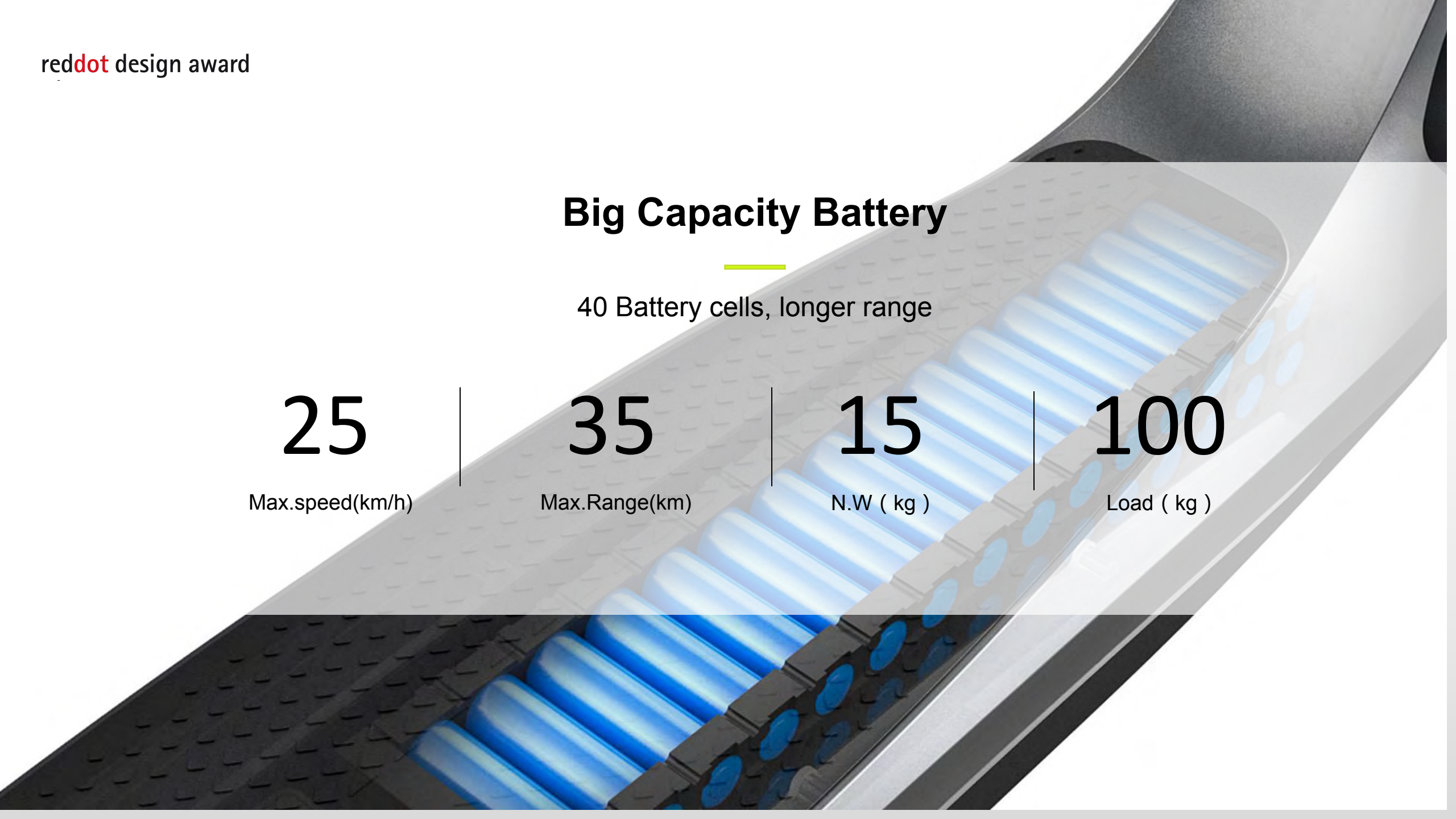

reddot design award

Intelligent BMS

6 intelligent protections for battery



Over current
protection



Short circuit
protection



Temperature
anomalyprotection



Over-charge
protection



Over-discharge
protection



Under-voltage
auto sleep

reddot design award

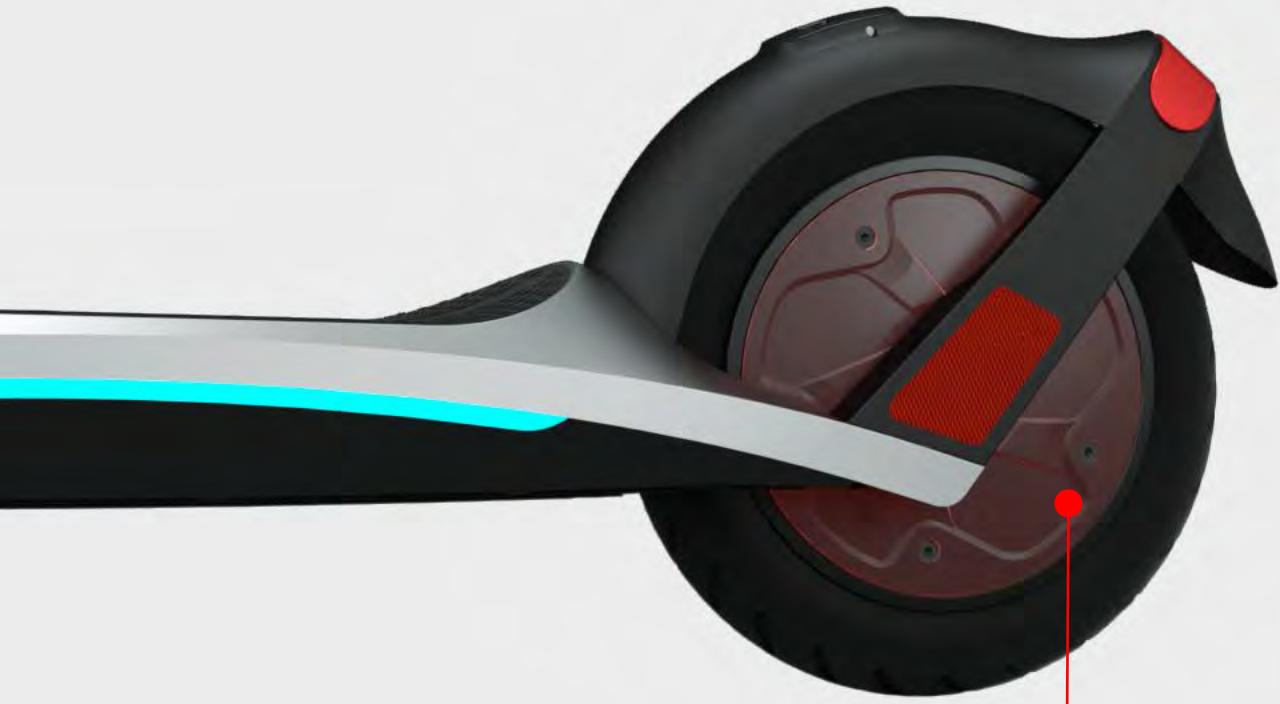

E-ABS Electronic Brake

Drum brake



reddot design award



Non-Pneumatic Tires

9 inch PU foamed tires.
Maintenance-free

reddot design award

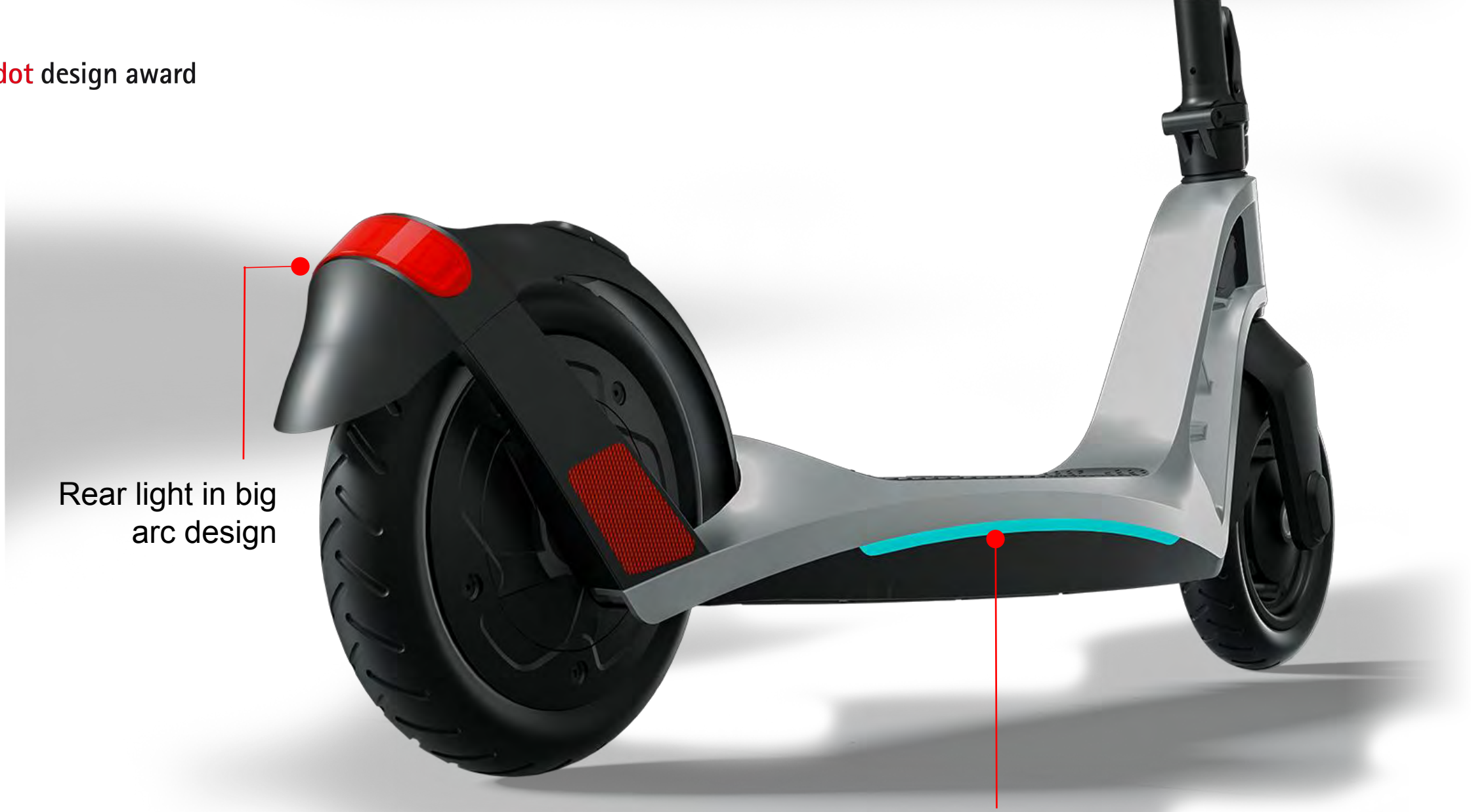

Rear light in big arc design

Streamlined Side Ambient lights

reddot design award

Germany ABE Version

Side reflector



K-mark Certificated

License Plate

reddot design award



LED Screen

High brightness, attractive interface.



K-mark Certificated Headlamp

Super bright at night



Powerful Motor

Rated power 300W, max. power 450W

reddot design award



reddot design award



SPECIFICATION		
Frame	Material	Magnesium alloy
Front fork	Material	Steel
Battery	Capacity	36V 7.5Ah/10Ah
Parameters	Max.speed	25 (Km/h)
	Max.range	7.5Ah: 25km 10Ah: 35km
	Max.climb angle	14°
	Tire	Front & rear 9 inch (PU foamed inner tube. Flat-free)
	Brake	Front drum brake and rear E-ABS electronic brake
Config	Light	Front headlamp, rear light
	Dashboard	LED(Speed, power, range)
	Controller	FOC 36V,15A
	Ambient light	on right & left side
Motor	Power	300W rear drive
Charger	Output voltage	DC42V,2A
Package size	L*W*H	1125*180*505mm
Container load	40HQ Container	660pcs (without pallet)

N2 Electric Scooter (10inch)







Integrated Moulding Frame



Die-casting Magnesium Alloy: light-weight & high strength

Patented design folding mechanism
meets new EN17128 standard;

3 Seconds Fast Folding

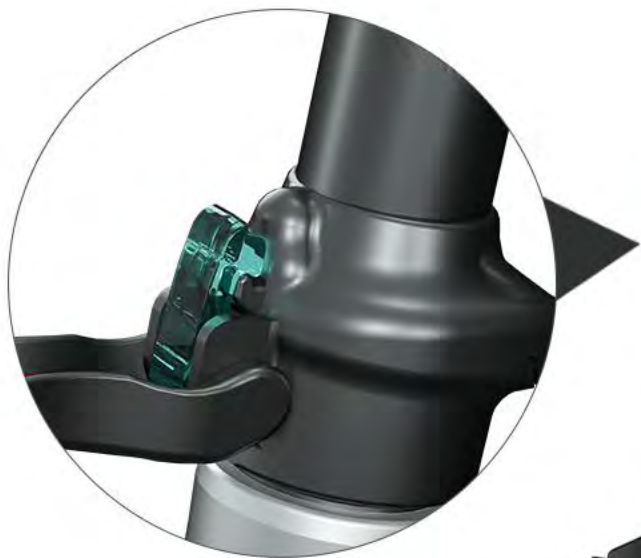

Big Capacity Battery

52 Battery cells, longer range

25-35

Max.speed(km/h)

45

Max.Range(km)

20

N.W (kg)

120

Load (kg)

Intelligent BMS

6 intelligent protections for battery



Over current protection



Short circuit protection



Temperature anomaly protection

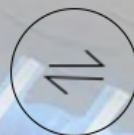

Over-charge protection



Over-discharge protection



Under-voltage auto sleep

K-mark Certificated Rear light

License Plate





Rear disc brake



Rear spring suspension



Front suspension



Drum brake



LED Screen

High brightness, attractive interface.











K-mark Certificated Headlamp

—
Super bright at night

















SPECIFICATION		
Frame	Material	Magnesium alloy
Front fork	Material	Steel
Battery	Capacity	36V 7.5Ah/10Ah or 48V 10.4Ah
Parameters	Max.speed	25-35 (Km/h)
	Max.range	7.5Ah: 25km. 10Ah:33km. 48v 10.4Ah:45km
	Max.climb angle	15-18°
	Tire	Front & rear 10 inch (Pneumatic Tire)
Config	Brake	Front drum brake and rear Disc brake
	Light	Front headlamp, rear light (k- mark)
	Dashboard	LED(Speed, power, range)
	Controller	FOC 36V/48V,21A
	License plate holder	on rear
Motor	Power	36V/48V, 350-500W motor for choosing
Suspension	Suspension	Front and rear suspension













E-SCOOTER

	MODEL	PICTURE	TECHNICAL DETAILS	PRICE IN USD	QTY PER 40HQ
1	S7		Aluminum alloy frame Front drum brake and rear disc brake 350W rear drive 36V/7.5AH		
2	SC3		Magnesium alloy frame Front drum brake and rear E-ABS electronic brake 300W rear drive 36V/7.5AH, 30cells Pneumatic tire Single wheel type		
3	HSC4		Magnesium alloy frame Front drum brake and rear E-ABS electronic brake 300W rear drive 36V/10AH, 40cells Pneumatic tire Single wheel type		
4	HC4		Magnesium alloy frame front drum brake and rear disc brake 350W rear motor 36V / 10AH, 40 cells lithium battery pneumatic tire		
5	HC5		Magnesium alloy frame Front drum brake and rear disc brake 500W rear drive 48V/10.4AH, 52cells Pneumatic tire		
6	HC3		Magnesium alloy frame Front drum brake and rear disc brake 350W rear drive 36V/7.8AH, 30cells Pneumatic tire		
7	HC40		Magnesium alloy frame Front drum brake and rear disc brake 500W rear drive 36V/10AH, 40cells Pneumatic tire		
8	HD 5		Magnesium alloy frame Front drum brake and rear E-ABS electronic brake 400W rear drive 48V / 10.4AH lithium battery PU foamed tire		

SHARED EBIKE



Electric System								
	Motor:	48V350W Rear Motor		Battery:	48V20Ah Lithium battery		Charger:	Yes
	Motor position	Rear Motor		Display:	NO		Throttle	Yes
	Battery Position	S/T		Controller:	48V 18A		Max speed	25KM/H
Main Components								
	Frame:	16" Q195 carbon steel		Gear	NO		Seat	Soft comfortable
	Fork:	Steel		Spoke:	Stainless steel		Seat post	Alloy

	Derailleur:	NO		Tyre:	16/2.5"		Lights	Yes
	Crank:	NO		Handle bar	Alloy		Chain	Yes
	Brake lever	Plastic brake lever		Stem	Alloy		Rear rack	NO
	Brakes:	Drum Brake		Fenders:	Yes		Pedal	NO
Packing		Performance			Size	Others		
G.W.:		Charging time:	6-9h					
N.W.:	52KG	Recharging cycles:	>=800 times	165-190CM	Color	Yellow		
Material:	Strong Carton	Max speed:	25KM/H		Fold	Yes		
Carton size:		Range per charge:	45KM		Capacity	30000pcs/Month		
Container QTY:	units/20'GP units/40'HQ	Loading capacity:	150kg		Smart Type	Electronic		